



AF/50/5, AF/100/10 AF IEPE Impedance Head

5mV/N / 50mV/g • 10mV/N / 100mV/g
121°C Max temp • 30gm

The AF/50/5 and AF/100/10 IEPE Impedance heads integrates an IEPE accelerometer and force sensor into one device to measure dynamic acceleration and force simultaneously.

The AF impedance head is manufactured in stainless steel, has a mass of 30 grams and an operating temperature range of -40 to +121°C (-40 to +249°F). IEPE sensitivity options including 5mV/N and 10mV/N for measuring force and 50mV/g and 100mV/g for acceleration dependent on your requirements.

With a low impedance voltage mode and an effective anti-jamming facility the AF impedance head is ideal for use in modal and structural analysis. It can be attached to an input stinger that is itself driven by a modal shaker and also attached to the test structure via the two M5 tapped mounting holes. The use of IEPE sensors provides accurate measurement of applied forces over a wide bandwidth providing extensive excitation range for Modal testing, unlike other strain gauge sensors which are used for static and quasistatic environments.

As with all IEPE sensors, setup is easy and the AF can be connected directly to a data acquisition and analysis system equipped with IEPE signal conditioning within the range of 2-10mA and 18-28VDC. Cables of any length can also be supplied to suit all test set ups and the calibration certification supplied provides National traceability.

	AF/50/5	AF/100/10
Sensitivity (20°C) Force ±10	5mV/N	10mV/N
Sensitivity (20°C) Acceleration ±10	50mV/g	100mV/g
Measuring Range Force	1000N	500N
Measuring Range Acceleration	±100g	±50g
Typical Frequency Range Force	~ 55kHz	~ 0.5Hz~ 5kHz
Typical Frequency Range Acceleration	~ 55kHz	~ 0.5Hz~ 5kHz
Temperature Range	-40 to +121°C	
Weight	30gms	
Case material	Stainless steel	
Mounting Type	x2 M5	
Dimensions	20 x 27mm	
Output impedance	<100Ω	

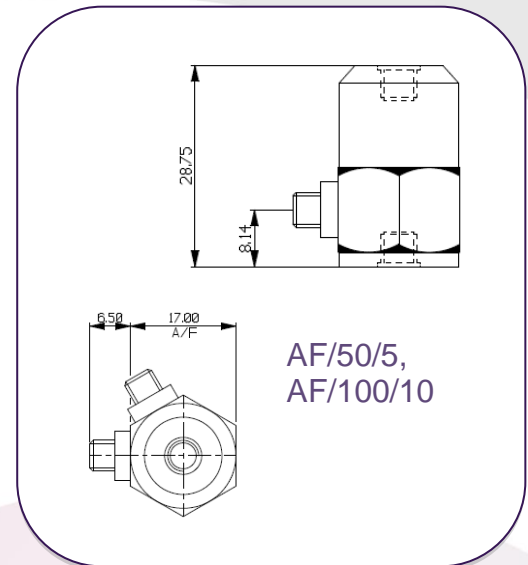

Typical Frequency Response

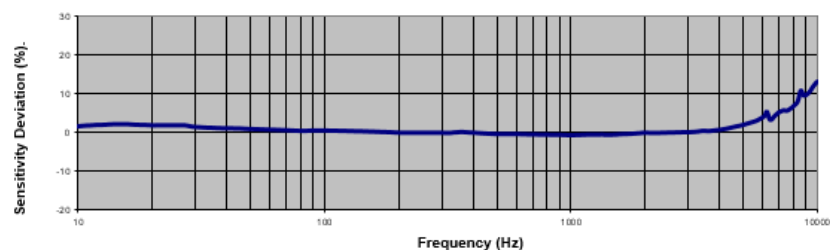

Options

M5/BC1/S18/30 –
3 metre cable

M5/BC1/S18/50 –
5 Metre cable

DJB Instruments (UK) Ltd

Finchley Avenue,
Mildenhall, Suffolk IP28 7BG

A UK company with UK-based manufacturing, assembly and calibration in-house.

Tel +44 (0)1638 712 288
Email sales@djbinstruments.com
Web www.djbinstruments.com

DJB Iss.1

